

Partial Discharge Monitoring and Diagnostic tools for Power Plants

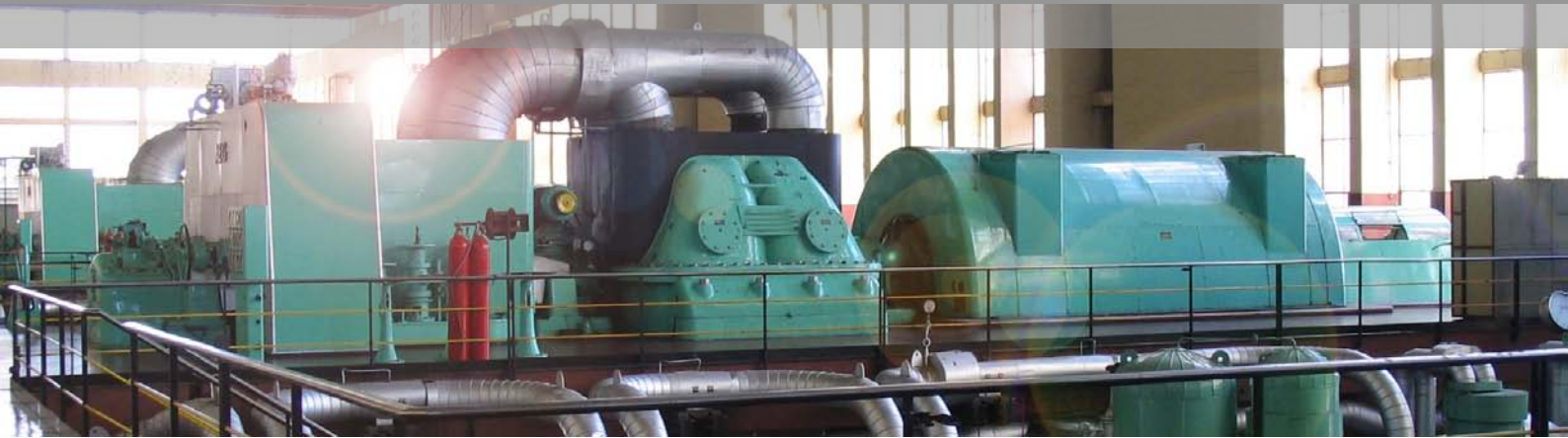

Take advantage of Techimp GLOBAL Monitoring System “diagnostics all in one”

Introduction:

Diagnostic tools for Generator Power Plants

In the last years many economic sectors have been deeply restructured under a wave of competition and privatization. As a result, operators need to be able to face shrinking revenues and limited investment possibilities. Maintenance practices have been, consequently, radically changed.

Electrical Utilities (power generation, transmission, and distribution) need to optimise their resources, extend the life of their equipment and reduce the budget for maintenance activities. On the other hand utilities have to comply with continuity and power quality requirements, thus minimising the impact of outages which can have serious consequences from a technical and a financial point of view.



Usually electrical installations undergo a Time Based Maintenance (TBM) program at fixed time intervals. However, for the most critical equipments, a Condition Based Maintenance (CBM) is much more advisable. Applying CBM means to keep the electrical equipment under control in order to continuously monitor its state. This is done to detect potential sources of problems at a very early stage and to take the relevant countermeasures well before irreversible and harmful events happen. By means of CBM, therefore, long forced stops can be avoided, thus limiting costs due to loss of revenues and repair after failure.

Insulation breakdown generally is the main cause of outage of electrical apparatus.

Degradation phenomena associated with defects already existing in the insulation system, introduced during on field assembly of an electrical apparatus or grown by insulation aging, can be diagnosed often by means of Partial Discharge (PD) measurement and analysis.



Introduction:

Diagnostic tools for Generator Power Plants

PD measurements can be carried out both on-line with the equipment under test supplied by the electric network and off-line, with the electrical system supplied by an external voltage source. Thus, off-line tests can be carried out only periodically, when the plant operation is stopped.

Therefore, **the ideal solution for the prevention of electrical asset failures is permanent on-line PD monitoring.**

Techimp Systems has developed innovating technologies and devised dedicated solutions in order to keep the insulation and the functionality of any electrical equipment always under control.

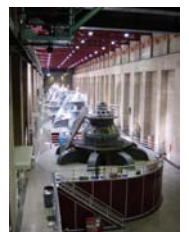

As a matter of fact, Techimp monitoring systems represent the ideal and ultimate solution for the CBM of electrical apparatus.

Techimp innovative technology for Partial Discharge detection and analysis

Techimp technology allows different Partial Discharge (PD) phenomena to be classified on the basis of their pulse shape and split in different clusters (TF map[®]), so that further analysis can be carried out on each dataset, separately. This enhances the likelihood of PD source identification, even for non skilled operators.

On the basis of the TF map[®], it is possible to achieve noise rejection and separation of PD phenomena. An example of this separation for a power generator is shown in the picture below, in which PD due to different phenomena group into different clusters. After the separation has been carried out, patterns associated to each phenomenon can be extracted and processed separately, the identification of the phenomena causing PD can be carried out through artificial intelligence techniques.

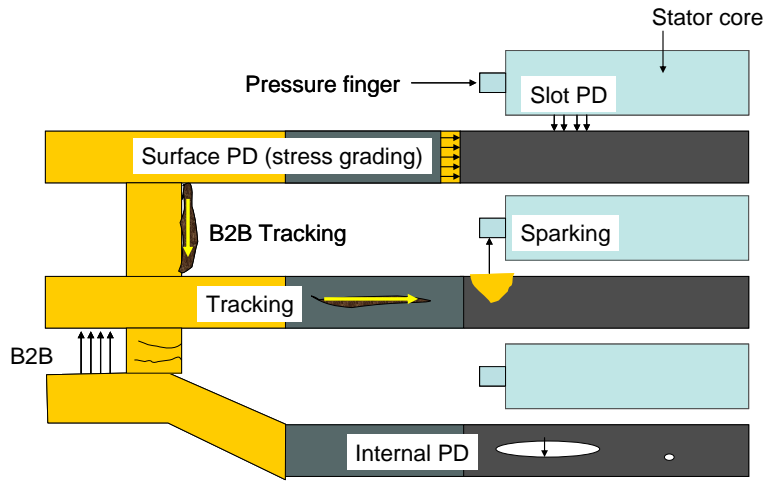

Possible defects and PD sources in a rotating machine

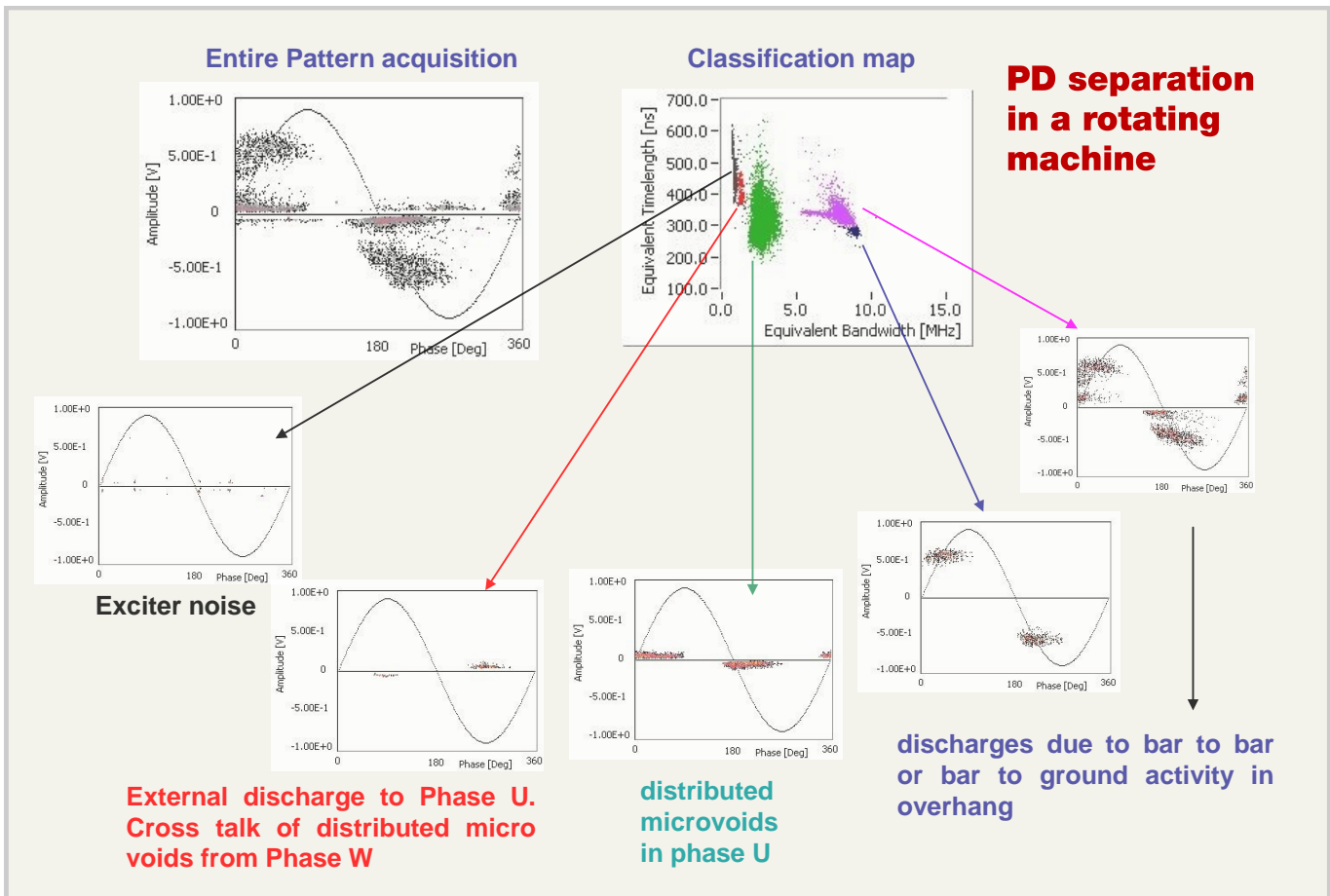

Example of PD separation in a rotating machine

Partial Discharge monitoring system

The system is aimed at acquiring, processing and analysing partial discharge pulses originated in the MV/HV electrical equipments , e.g.:

- **Generators (G)**
- **HV/MV Cables (C)**
- **Step-up transformers (T)**
- **MV Motors (M)**
- **Switchboards & GIS**
- **Measurement transformers**

Since Partial Discharges are symptoms of degradation of the insulation, the system hereby described is able to keep the insulation of the electrical systems permanently under control and give an alarm in case PD phenomena become potentially dangerous for any equipment.

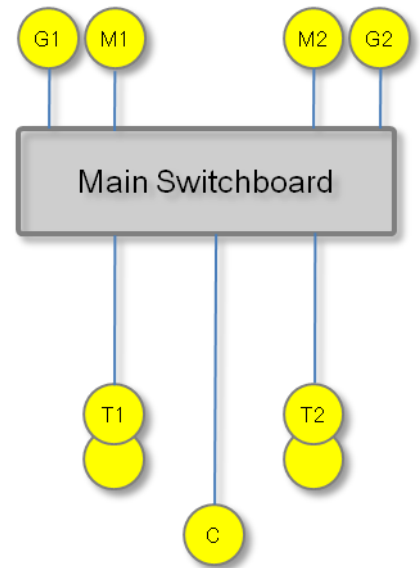

System Architecture

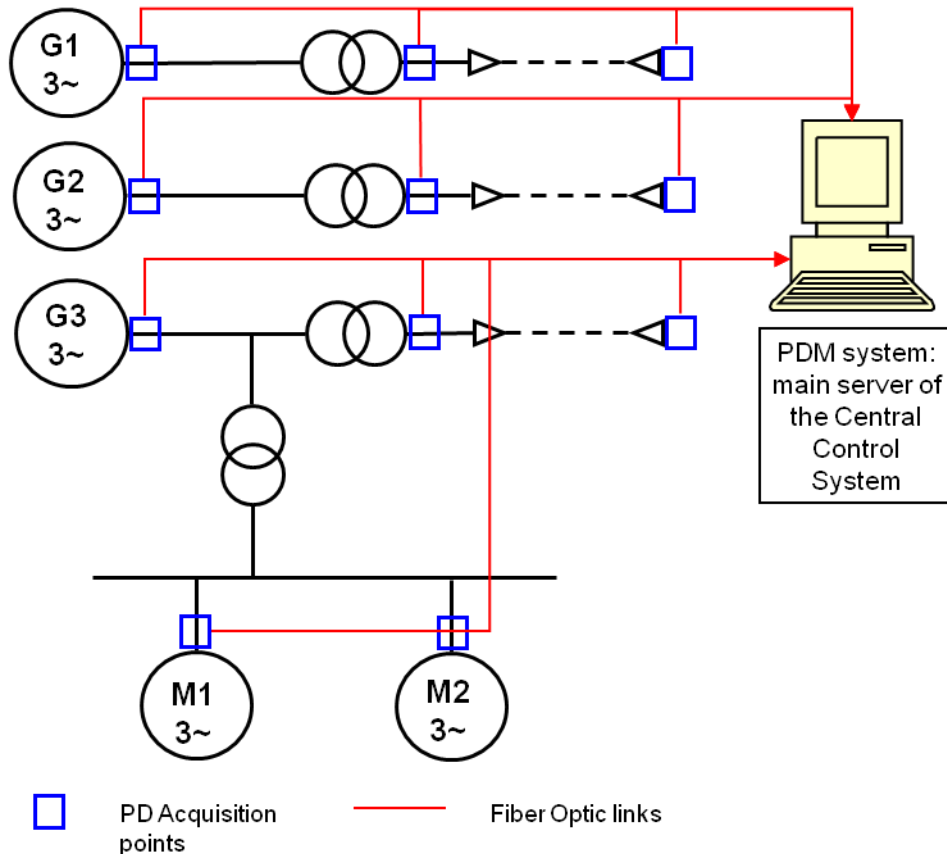

Example of system architecture

Partial Discharge monitoring system

The PD Monitoring system consists of:

Sensors & Couplers as PD sensors (e.g. capacitive coupler for motors and generators)

Partial Discharge Detection Points, equipped with a “PDscope”, an Ethernet Switch and a power supply and signal conditioning device;



PDscope

Fibre optic Communication Network for the signal transmission, to link the detection points and the central control system. The communication network is based on the *Link Loss Learn* technology which, in case of failure in one point of the network, allows restoring the connection on an alternative data route, thus improving the system reliability;

Central Control System. It includes one Server with software to manage the whole system and a database for PD data.

Main system features:

Digitizer. Each acquisition point is provided with a peak detector system for a fast pattern detection, as well as with a 100MS/s digitizer, so that it is possible to acquire the complete waveform of each PD signal in order to separate and identify efficiently different PD activities (bandwidth from 10KHz to 40 MHz).

Separation and Noise rejection. Thanks to the Techimp innovative technology based on pulse analysis (TF map[®]), the system is ideal for “on-line” application, since its unique features allow an excellent noise and disturbance rejection, as well as separation of different PD phenomena.

System modularity and possibility of further expansions. The system can be easily expanded. There is no theoretical limit of the acquisition units which may be connected to the same control system: PD sensors and acquisition units can be installed on any electrical assets of the electrical system, such as **generators, motors, main switchboard, distribution transformers, measurement transformer and cable links.**

PD activity at a glance. The supervision & control system allows the operator to check the situation and the PD activity of all the electrical apparatus in the electrical system.

Alarms. General alert and smart alerts based on identified insulation defects.

Diagnostic data-base. Possible cross correlations among the stored data, to be customized on the basis of customer requirements or according to peculiar findings.

Take advantage of Techimp GLOBAL Monitoring Systems on line diagnostics all in one

Based on multiple on-line diagnostic advanced techniques

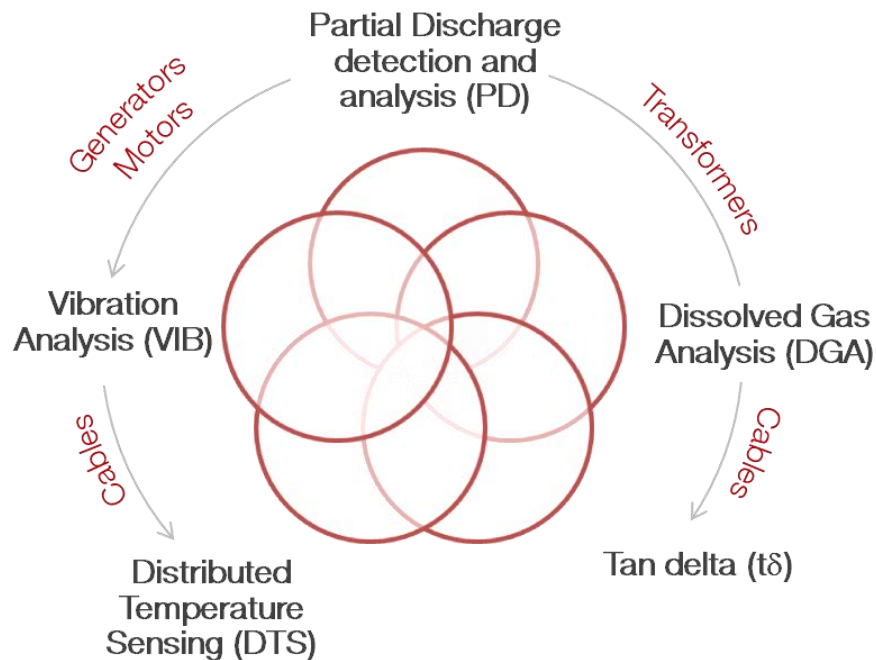

1 detector
many
sensor types

On line diagnosis of ALL electrical apparatus

Our Vision:

Apparatus

- ✓ Multiple subsystems
- ✓ Multiple failure modes

Approach

- ✓ One apparatus where multiple sensors provide complementary information
- ✓ Shrink monitoring costs
- ✓ Exploit synergies between information provided by different diagnostic techniques
- ✓ Enhance diagnostic capability and apparatus reliability
- ✓ Reduce overall maintenance costs

For news and further information please visit us at www.techimp.com

www.techimp.com